

OSO

Ultra-Wide View High-Resolution Imaging Lidar

SUMMARY

The OSO offers an ultra-wide 95° vertical field-of-view with an industry-leading combination of price, performance, reliability, size, weight, and power. It is designed for indoor/outdoor all-weather environments and long lifetime. As the smallest high performance lidar on the market, the OSO can be easily integrated into autonomous vehicles, heavy machinery, robots, drones, and mapping solutions.

HIGHLIGHTS

- Fixed resolution per frame
- Camera-grade ambient and intensity data
- Multi-sensor crosstalk immunity
- Industry-leading intrinsic calibration
- Open source drivers

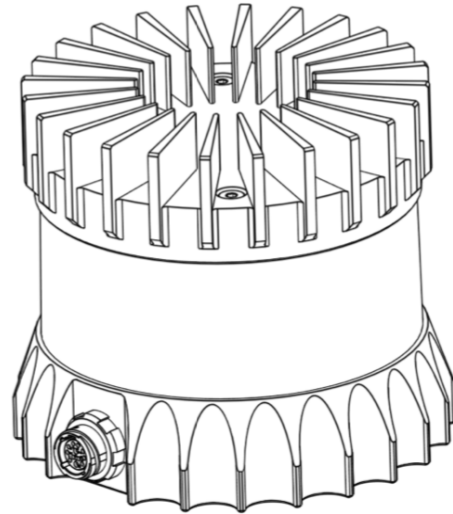

OPTICAL PERFORMANCE

Range (80% Reflectivity)	0.25 m - 55 m @ 80% reflective lambertian target, 100 klx sunlight, >50% detection probability, false positive rate of 1/10,000 0.25 m - 50 m @ 80% reflective lambertian target, 100 klx sunlight, >90% detection probability, false positive rate of 1/10,000
Range (10% Reflectivity)	0.25 m - 20 m @ 10% reflective lambertian target, 100 klx sunlight, >50% detection probability, false positive rate of 1/10,000 0.25 m - 15 m @ 10% reflective lambertian target, 100 klx sunlight, >90% detection probability, false positive rate of 1/10,000
Range Accuracy	<5 cm for lambertian targets, <10 cm for retroreflectors
Range Resolution	0.3 cm
Range Repeatability/Precision (1 sigma / standard deviation)	0.25 - 15 m: ± 1.5 cm; 15 - 50 m: ± 2 cm; >50 m: ± 5 cm
Vertical Resolution	32, 64, or 128 channels
Horizontal Resolution	512, 1024, or 2048 (configurable)
Field of View	Vertical: 95° (+47.5° to -47.5°) Horizontal: 360°
Angular Sampling Accuracy	Vertical: ±0.01° / Horizontal: ±0.01°
Rotation Rate	10 or 20 Hz (configurable)
# of Returns	1 (strongest)

LASER

Laser Product Class	Class 1 eye-safe per IEC/EN 60825-1: 2014
Laser Wavelength	865 nm
Beam Diameter Exiting Sensor	5 mm
Beam Divergence	0.35° (FWHM)

LIDAR OUTPUT

Connection	UDP over gigabit Ethernet
Points Per Second	655,360 (32 channel) 1,310,720 (64 channel) 2,621,440 (128 channel)
Data Per Point	Range, intensity, reflectivity, ambient, channel, azimuth angle, timestamp
Timestamp Resolution	< 1 μ s
Data Latency	< 10 ms

IMU OUTPUT

Connection	UDP over gigabit Ethernet
Samples Per Second	100
Data Per Sample	3 axis gyro, 3 axis accelerometer
Timestamp Resolution	< 1 μ s
Data Latency	< 10 ms
Additional Details	InvenSense ICM-20948; datasheet for more details: https://www.invensense.com/products/motion-tracking/9-axis/icm-20948/

CONTROL INTERFACE



Connection	TCP and HTTP APIs
Time Synchronization	Input sources: <ul style="list-style-type: none">• IEEE1588 Precision Time Protocol (PTP)• NMEA \$GPRMC UART message support• External PPS• Internal 10 ppm drift clock Output sources: <ul style="list-style-type: none">• Configurable 1 - 60 Hz output pulse
Lidar Operating Modes	Hardware-triggered angle firing (guaranteed fixed resolution per rotation): <ul style="list-style-type: none">• x 512 @ 10 Hz or 20 Hz• x 1024 @ 10 Hz or 20 Hz• x 2048 @ 10 Hz
Additional Programmability	Multi-sensor rotation phase tuning Queryable intrinsic calibration information: <ul style="list-style-type: none">• Beam angles• IMU pose correction matrix

MECHANICAL/ELECTRICAL

Power Consumption	14 - 20 W (22 W peak at startup)
Operating Voltage	22 - 26 V, 24 V nominal
Connector	Proprietary pluggable connector (Power + data + DIO)
Dimensions	Diameter: 85 mm (3.34 in) Height: <ul style="list-style-type: none">• Without cap: 58.35 mm (2.3 in)• With thermal cap: 73.5 mm (2.9 in)
Weight	Without cap: 368 g (13.0 oz) With radial cap: 445 g (15.7 oz)
Mounting	Bottom: 4x M3 screws, 2x locating 2 mm pin holes Top: 4x M3 screws, 4x locating 2 mm pin holes, 1x M6 screw

OPERATIONAL

Operating Temperature	-20°C to +50°C (with mount)
-----------------------	-----------------------------

Storage Temperature	-40°C to +105°C
Ingress Protection	IP68 (1m submersion for 1 hour, with I/O cable attached) IP69K (with I/O cable attached)
Shock	IEC 60068-2-27 (Amplitude: 100 g, Shape: 11 ms half-sine, 3 shocks x 6 directions) IEC 60068-2-29 (Amplitude: 40 g, Shape: 6 ms half-sine, 1,500 shocks x 6 directions)
Vibration	IEC 60068-2-64 (Amplitude: 3 G-rms, Shape: 10 - 1000 Hz, Mounting: sprung masses, 3 axes w/ 8 hr duration each)
Compliance	<p>Laser Safety:</p> <ul style="list-style-type: none"> • IEC/EN 60825-1:2014 Class 1 eye safe (pending) • US 21CFR1040: Complies with FDA performance standards for laser products except for deviations pursuant to Laser Notice No. 56, dated May 8th, 2019 (pending) <p>Product Safety: IEC/EN 62368-1:2014</p> <p>EMC (all pending):</p> <ul style="list-style-type: none"> • FCC 47Cfr Part 15B, Class A • EN 55032: 2012/AC: 2013, Class A • IEC/EN 61000-4-3,4,5,6 • IEC/EN 61000-6-2:2005 Class A • IEC/EN 61000-6-4: 2007 <p>  (pending)</p>

ACCESSORIES

Included Interface Box	Polycarb/FR4, 100 g, 75 mm x 50 mm x 25 mm (LxWxH), 2 m CAT6 cable, 24 V power adapter, 5 m sensor cable
Optional Mount	Aluminum, 530 g, 110 mm x 110 mm x 20.5 mm (LxWxH), 4 x M8 thru holes

EXTERIOR DIMENSIONS

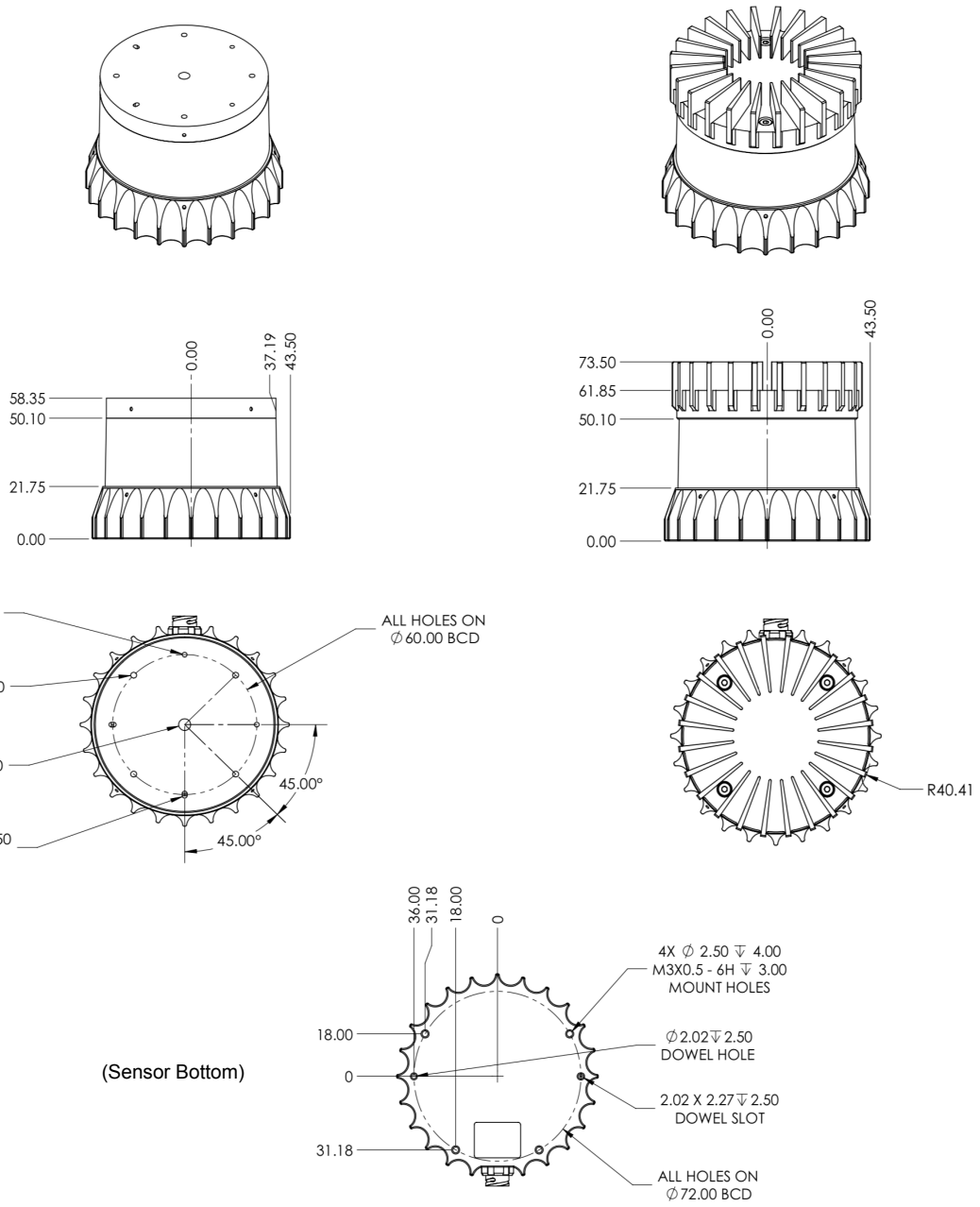

*Specifications are subject to change without notice.

WWW.OUSTER.COM

REV: 2/26/2020 • © 2020 Ouster, Inc. • All rights reserved