



OS-1-64/16 High Resolution Imaging Lidar

Hardware User Guide

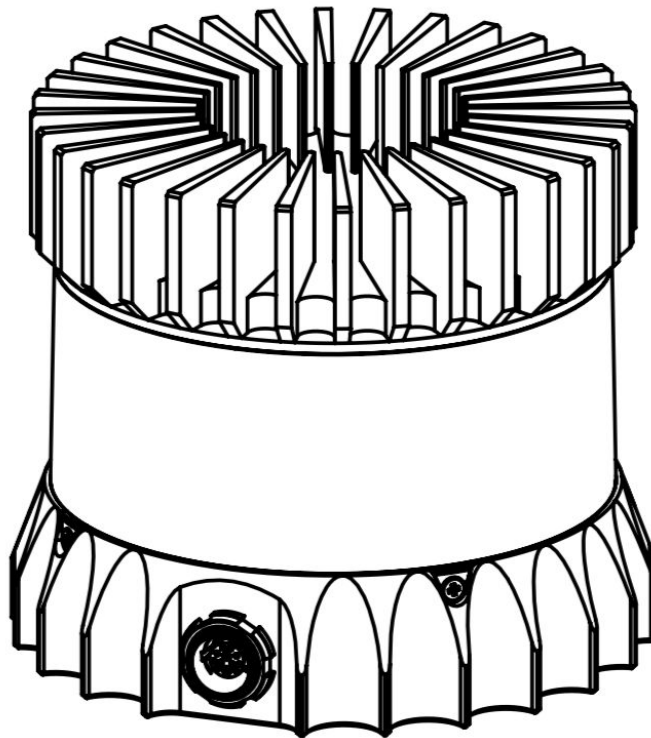



Table of Contents

Introduction	3
Safety & Legal Notices	3
Set-Up	4
Included Components	4
Exterior Mechanical Dimensions	5
Heat Sink Requirements	6
Interface Box	6
Drivers & Interface	8
Updating Firmware	8
Troubleshooting	8
Specifications	10



1 Introduction

The OS-1 family of sensors offer a market leading combination of price, performance, reliability and SWAP. They are designed for indoor/outdoor all-weather environments and long lifetime. As the smallest high performance lidar on the market, the OS-1 can be directly integrated into vehicle facias, windshield, side mirrors, and headlight clusters. The OS-1 family of sensors consist of two models, the OS-1-16 and OS-1-64, with differing resolution, but of identical mechanical dimensions.

HIGHLIGHTS

- Fixed resolution per frame operating mode
- Camera-like intensity, ambient, and range images
- Simultaneous and co-calibrated 2D and 3D output
- Multi-sensor crosstalk immunity
- Industry leading intrinsic calibration
- Open source drivers

For the purposes of this document, the term “OS-1” refers to the family of sensors, and only where there is a difference in performance will each model will be referred to by its specific model designation.

2 Safety & Legal Notices

The OS-1-16 and OS-1-64 are Class 1 laser products per **EN/IEC 60825-1:2014** and operate in the 850nm band.

FDA 21CFR1040 Notice: OS-1-16 and OS-1-64 comply with FDA performance standards for laser products except for deviations pursuant to Laser Notice No. 50, dated July 26th, 2001.





WARNING: The OS-1 is a sealed unit, and is not user-serviceable.

Your use of the OS-1 is subject to the Terms of Sale that you signed with Ouster or your distributor/integrator. Included in these terms is the prohibition on removing or otherwise opening the sensor housing, inspecting the internals of the sensor, reverse-engineering any part of the sensor, or permitting any third party to do any of the foregoing.

“Ouster” and “OS-1” are both registered trademarks of Ouster. They may not be used without express permission from Ouster.

If you have any questions about the above points, contact us at legal@ouster.io.

3 Set-Up

3.1 Included Components

The OS-1 is shipped with the following items:

- OS-1-16 or -64 Sensor
- Sensor to interface box cable/connector
- Interface box
- Interface box AC/DC power supply (2 meters)
- RJ45 cable (1 meter)
- Optional: Heat sink

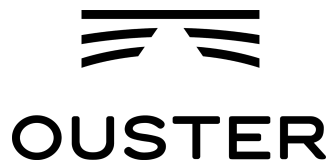

3.2 Exterior Mechanical Dimensions

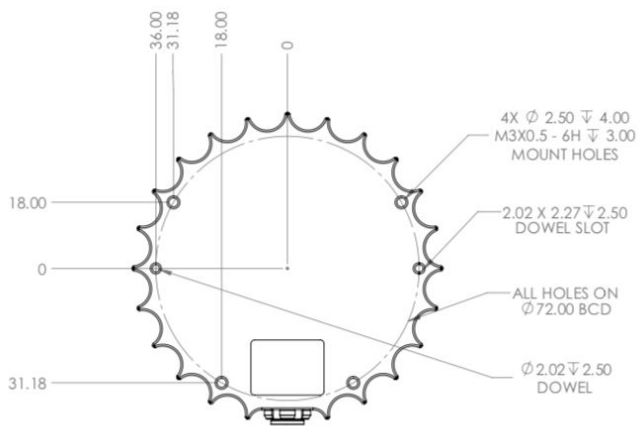
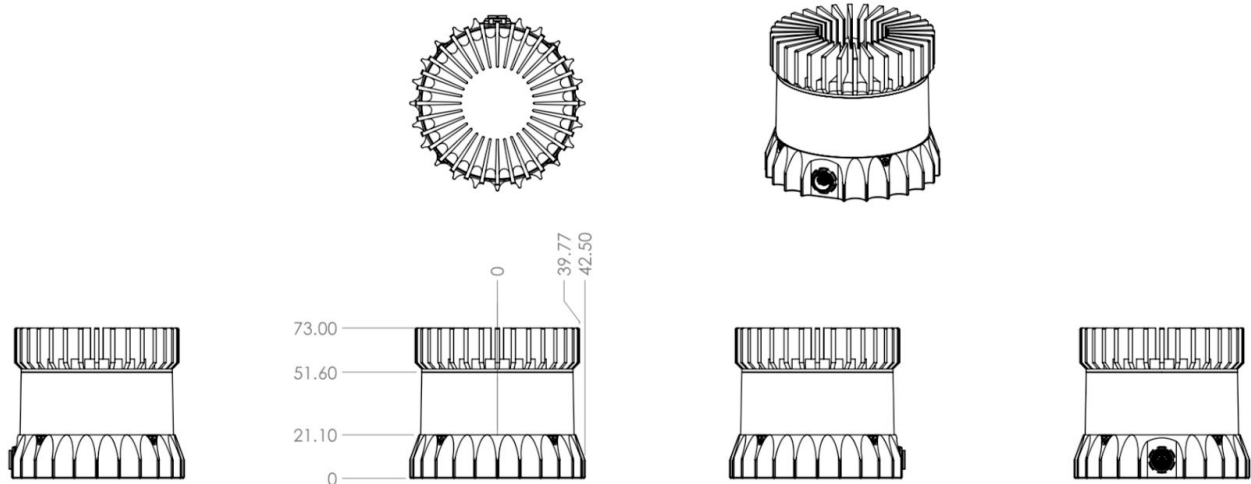

The sensor has 4 x M3 mounting holes and 2 x 2.0 mm dowel pin holes

3.3 Heat Sink Requirements

The sensor typically consumes 14-16 Watts. The recommended T_{heatsink} is $< 25^{\circ} \text{C}$ above ambient -- meaning the sensor can get to $45\text{-}50^{\circ} \text{C}$ with a heat sink, or even higher, without performance degradation. A heat sink is required to achieve the full temperature spec of the sensor, though Ouster internal testing has shown that a heat sink may not be required for use on drones or other moderately or highly convective environments.

4 Interface Box

The Interface Box that accompanies the OS-1 sensor is designed to allow the sensor to be operated for test and evaluation purposes. It breaks out the OS-1 sensor cable, which is a combination of power and ethernet, into their two constituent connectors.

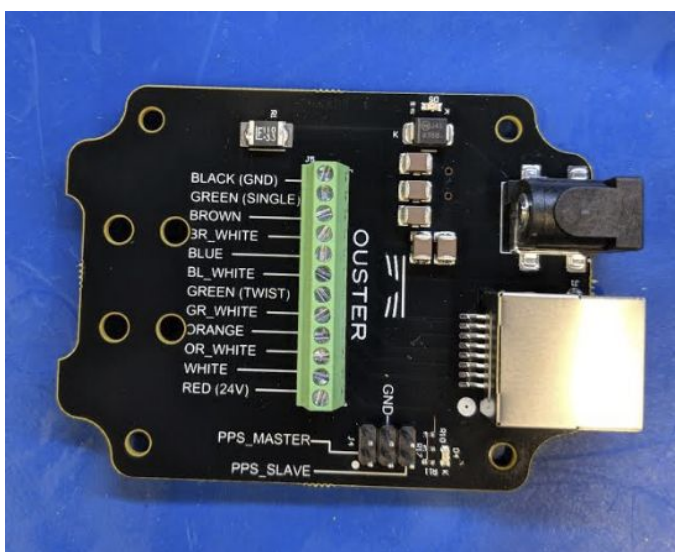
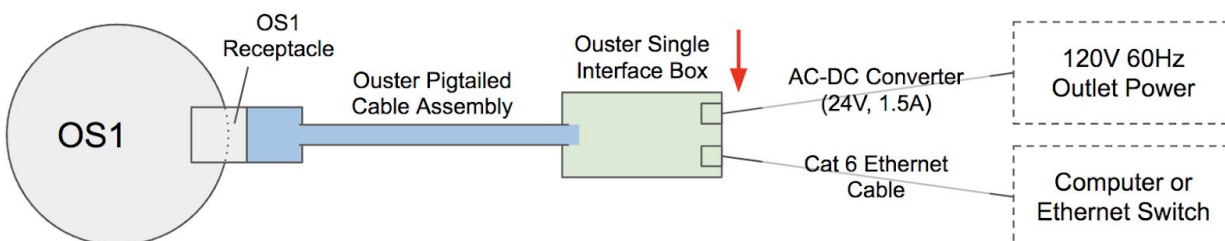

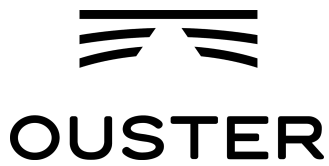

It terminates the interface cable from the sensor, allows it to be powered up and provides access to the Sensor Gigabit Ethernet Interface via a standard RJ-45 connector. DC Power to the sensor is provided to the interface box by the accompanying 24 V DC supply.

NOTE: If the sensor is not connected to Gigabit ethernet, it will stop sending data and will output an error code if the cabling is wired incorrectly and fails to achieve a 1000Mb/s + full duplex link.

The interface box is not necessary; a user can splice the wires directly into an RJ45 cable and connect the power wires directly to a 24V DC power supply. HOWEVER, Ouster is not responsible for any errors in wiring as a result of bypassing the interface box and this activity may result in a voiding of your warranty if it results in damage to the sensor.

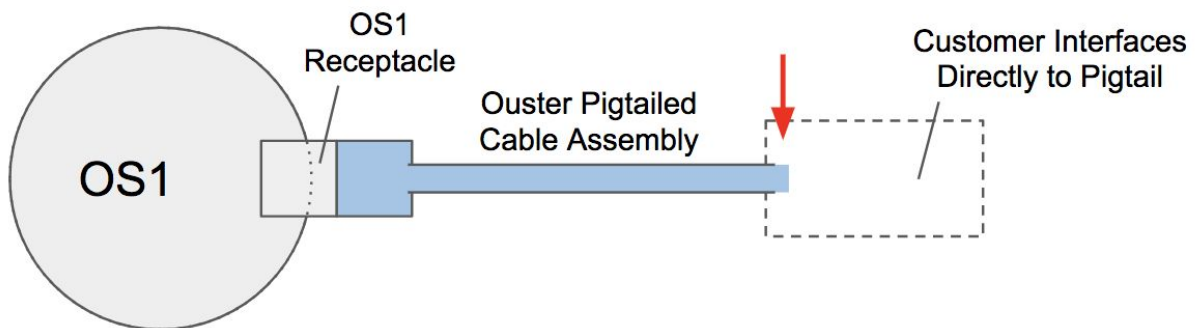

Connector Pinout			
Net Name	Pin Number	Wire	Twisted With
PPS_MASTER	Pin 1	Green, 28 AWG	N/A
PPS_SLAVE	Pin 9	White, 28 AWG	N/A
VCC_24	Pin 10	Red, 22 AWG	N/A
GROUND	Pin 5	Black, 22 AWG	N/A
GROUND (Additional)	Pin 13, Pin 14, Pin 15	N/A	N/A
TRP_1_P (Ethernet)	Pin 4	White/Orange, 28 AWG	Orange
TRP_1_N (Ethernet)	Pin 3	Orange, 28 AWG	White/Orange



OUSTER

TRP_2_P (Ethernet)	Pin 7	White/Green, 28 AWG	Green
TRP_2_N (Ethernet)	Pin 6	Green (twisted), 28 AWG	White/Green
TRP_3_P (Ethernet)	Pin 2	Blue, 28 AWG	White/Blue
TRP_3_N (Ethernet)	Pin 11	White/Blue, 28 AWG	Blue
TRP_4_P (Ethernet)	Pin 12	White/Brown, 28 AWG	Brown
TRP_4_N (Ethernet)	Pin 8	Brown, 28 AWG	White/Brown

The PPS Master and Slave pins operate at 5V

5 Drivers & Interface

The sensor will automatically turn on, start scanning, obtain an IP address, and start taking measurements when provided power by the Interface Box. However it will only stream UDP data packets after receiving a destination IP address on TCP Port 7501. Instructions can be found in the OS-1 Software User Guide and/or Ouster's drivers on GitHub (<https://github.com/ouster-lidar>).

6 Updating Firmware

The device can be updated over the local network. Refer to the Ouster Software User Guide for instructions.

7 Troubleshooting

Do not attempt to open or repair the sensor yourself. Opening or tampering with the sensor is a violation of the Ouster Terms and Conditions of Sale will result in voiding of your warranty.

- Check power and Ethernet connections the interface box.
- Power cycle the sensor.



OUSTER

If you are still having trouble with your sensor, call us at 1-415-594-4032 ext 444 or email us at support@ouster.io.

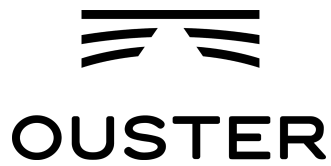

8 Specifications

OPTICAL PERFORMANCE

Range	0.5 m - 120 m @ 80% reflective lambertian target, 225 w/m2 sunlight, SNR of 12 0.5 m - 40 m @ 10% reflective lambertian target, 225 w/m2 sunlight, SNR of 12 ** range of 0.0-80m (min range of 0.0m) in enhanced low range mode
Range Accuracy	Zero bias for lambertian targets, slight bias for retroreflectors
Range Resolution	1.2 cm
Range Repeatability	SNR = 100: ± 3 cm - 1 sigma SNR = 12: ± 10 cm - 1 sigma
Vertical Resolution	OS-1-64: 64 OS-1-16: 16
Horizontal Resolution	512-2048 (configurable)
Field of View	Vertical: +16.6° to -16.6° (32.2°) OS-1-64: uniform spacing OS-1-16: multiple options, including uniform spacing, tight around the horizon, and below the horizon Horizontal: 360°
Angular Sampling Accuracy	Vertical: $\pm 0.01^\circ$ / Horizontal: $\pm 0.01^\circ$
Rotation Rate	10 to 20 Hz (configurable)
# of Returns	1 (strongest)

LASER

Laser Product Class	Class 1 eye-safe per IEC/EN 60825-1: 2014
Maximum output of Laser radiation	$< 100\mu\text{J}$
Laser Wavelength	850 nm
Beam Diameter Exiting Sensor	10 mm
Laser Pulse Width (FWHM)	8 ns
Beam Divergence	0.13° (FWHM)



LIDAR OUTPUT

Connection	UDP over gigabit ethernet
Point Per Second	OS-1-64: 1,310,720 OS-1-16: 327,680
Data Per Point	Range, intensity, ambient, reflectivity, angle, timestamp
Timestamp Resolution	10 ns
Data Latency	< 10 ms

IMU OUTPUT

Connection	UDP over gigabit ethernet
Samples Per Second	1,000
Data Per Sample	3-axis gyro, 3-axis accelerometer
Timestamp Resolution	10 ns
Data Latency	< 10 ms

CONTROL INTERFACE

Connection	TCP over gigabit ethernet
Time Synchronization	<p>Input sources:</p> <ul style="list-style-type: none"> • IEEE 1588 precision time protocol • External PPS • Internal 10 ppm drift clock <p>Output sources:</p> <ul style="list-style-type: none"> • Configurable 1-60 Hz output pulse
Lidar Operating Modes	<p>Hardware triggered angle firing:</p> <p>OS-1-64</p> <ul style="list-style-type: none"> • 64 × 2048 @ 10hz • 64 × 1024 @ 20hz • 64 × 1024 @ 10hz • 64 × 512 @ 20hz • 64 × 512 @ 10hz <p>OS-1-16</p> <ul style="list-style-type: none"> • 16 × 2048 @ 10hz • 16 × 1024 @ 20hz • 16 × 1024 @ 10hz • 16 × 512 @ 20hz



OUSTER

	<ul style="list-style-type: none"> • 16 × 512 @ 10hz <p>Each 50% the total number of points gathered is reduced - e.g., from 2048x10 to 1024x10 - extends range by 15-20%.</p> <p>Fixed timing firing:</p> <ul style="list-style-type: none"> • Configurable measurement period between 50 μsec and 1 sec and spin rates between 5 and 20hz.
Additional Programmability	<p>Multi-sensor rotation phase tuning</p> <p>Query-able intrinsic calibration information:</p> <ul style="list-style-type: none"> • Beam angles • IMU pose correction matrix

MECHANICAL/ELECTRICAL

Power Consumption	14-16 W typical, 18 W peak
Operating Voltage	22-26 V, 24 V nominal
Connector	Proprietary pluggable connector (Power + data + DIO)
Dimensions	Diameter: 85 mm (3.34 in) Height: 73 mm (2.87 in)
Weight	380 g (13.4 oz)
Mounting	4 x M3 screws / 2 locating 3 mm pins

OPERATIONAL

Operating Temperature	-20° C to +50° C with specified heat sink
Storage Temperature	-40° C to +105° C
Ingress	IP67
Shock	500 m/s ² amplitude, 11 ms Half Sine
Vibration	5 Hz to 2,000 Hz, 3 Grms
Compliance	<ul style="list-style-type: none"> • Laser Safety: <ul style="list-style-type: none"> ○ IEC/EN 60825-1:2014 Class 1 ○ US 21CFR1040: Complies with FDA performance standards for laser products except for deviations pursuant to Laser Notice No. 50, dated July 26th, 2001 • Product Safety: IEC/EN 62368-1:2014



OUSTER

	<ul style="list-style-type: none"> ● EMC: <ul style="list-style-type: none"> ○ FCC 47Cfr Part 15B, Class A ○ EN 55032: 2012/AC: 2013, Class A ○ IEC/EN 61000-4-3,4,5,6 ○ IEC/EN 61000-6-2:2005 Class A ○ IEC/EN 61000-6-4: 2007 ● CE Mark: Future ● ROHS
--	--

ACCESSORIES

Included Interface Box	PolyCarb/FR4, 100 g, 75 mm × 50 mm × 25 mm (L × W × H), 2 m CAT6 cable, 24 V power adapter, 5 m sensor cable
Optional Mount	Aluminum, 530, 100 mm × 100 mm × 20.5 mm (L×W×H), 4×M8 thru holes

EXTERIOR DIMENSIONS

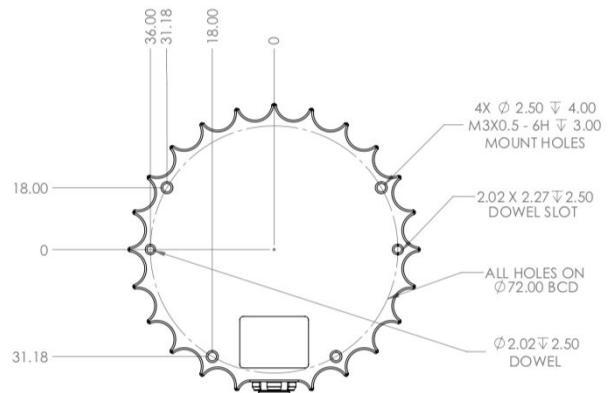
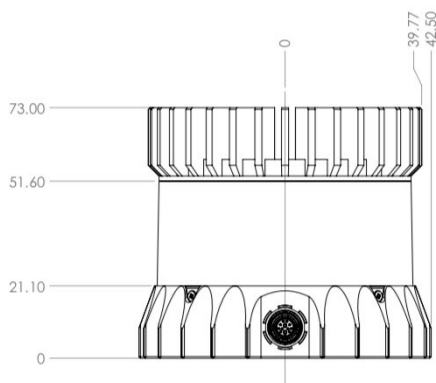

* Specifications are subject to change without notice.

WWW.OUSTER.IO